

REVISIONS				
P.	LTR.	DESCRIPTION	DATE	APPV.
K8		REVISED PER ECO-13-019565	12DEC2013	DD DS
K9		REVISED PER ECO-15-000100	22JAN2015	DD DS
K10		REVISED PER ECO-15-003872	25MAR2015	DD DS
K11		REVISED PER ECO-16-003526	09MAR2016	JM DS

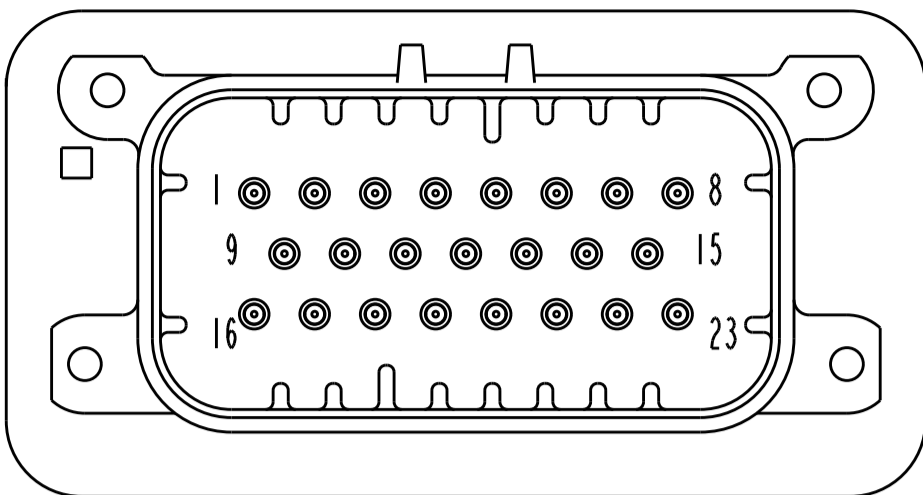

770669-2 & 1-770669-2
 KEY LOCATION
 SCALE 2:1

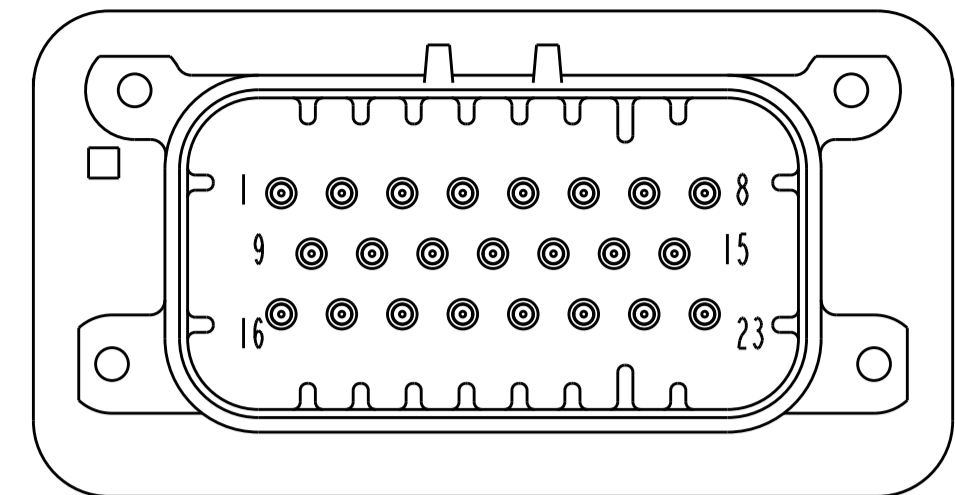

770669-4 & 1-770669-4
 KEY LOCATION
 SCALE 2:1

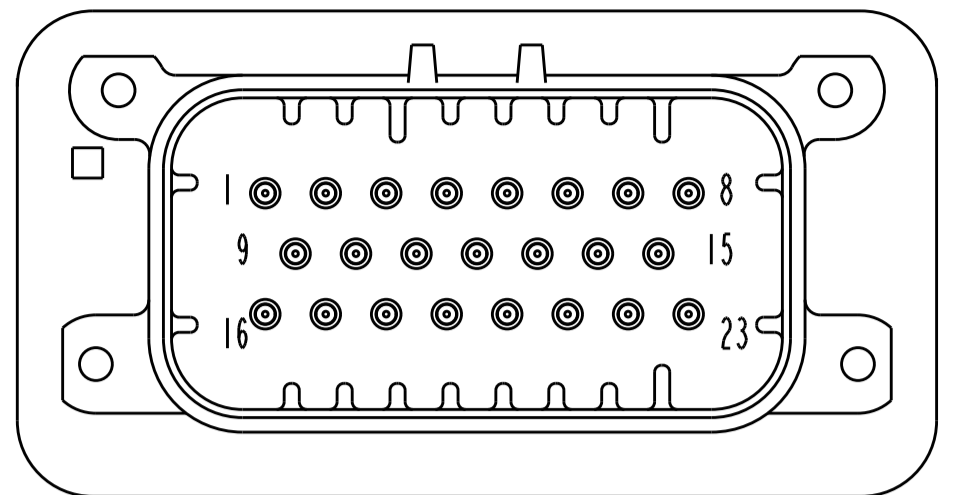

770669-5 & 1-770669-5
 KEY LOCATION
 SCALE 2:1

- 1 ACCEPTS #3 SELF TAPPING THREAD FORMING SCREWS OR METRIC EQUIVALENT. DRIVE TO 0.6-0.8 N-m.
- 2 DATE CODE TO BE BRANDED IN THIS LOCATION PER TE SPEC 102-60 USE 5 DIGIT CODE: FIRST 2 DIGITS = YEAR, SECOND 2 DIGITS = WEEK LAST DIGIT = DAY
- 3 HOUSING COLORS ARE MECHANICALLY KEYPED TO MATE ONLY WITH IDENTICALLY COLORED PLUG ASSEMBLIES.
- 4 MATERIALS: HEADER HOUSING - GLASS FILLED PBT
 PINS: TIN OR GOLD PLATED BRASS
- 5. HEADER MATES TO PLUG ASSEMBLY 770680 WHICH USES REELED TERMINALS 770520 OR LOOSE PIECE TERMINALS 770854

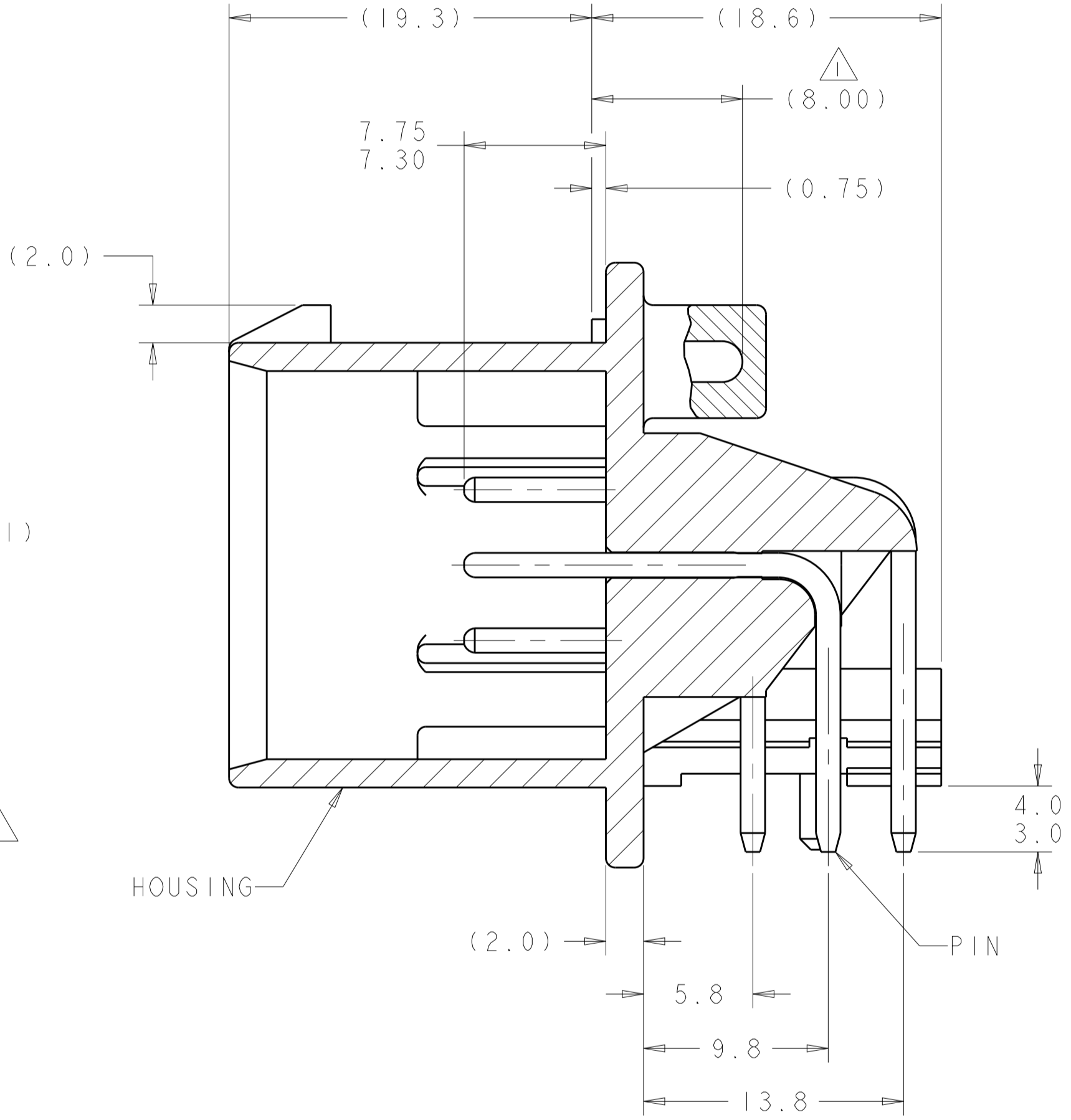
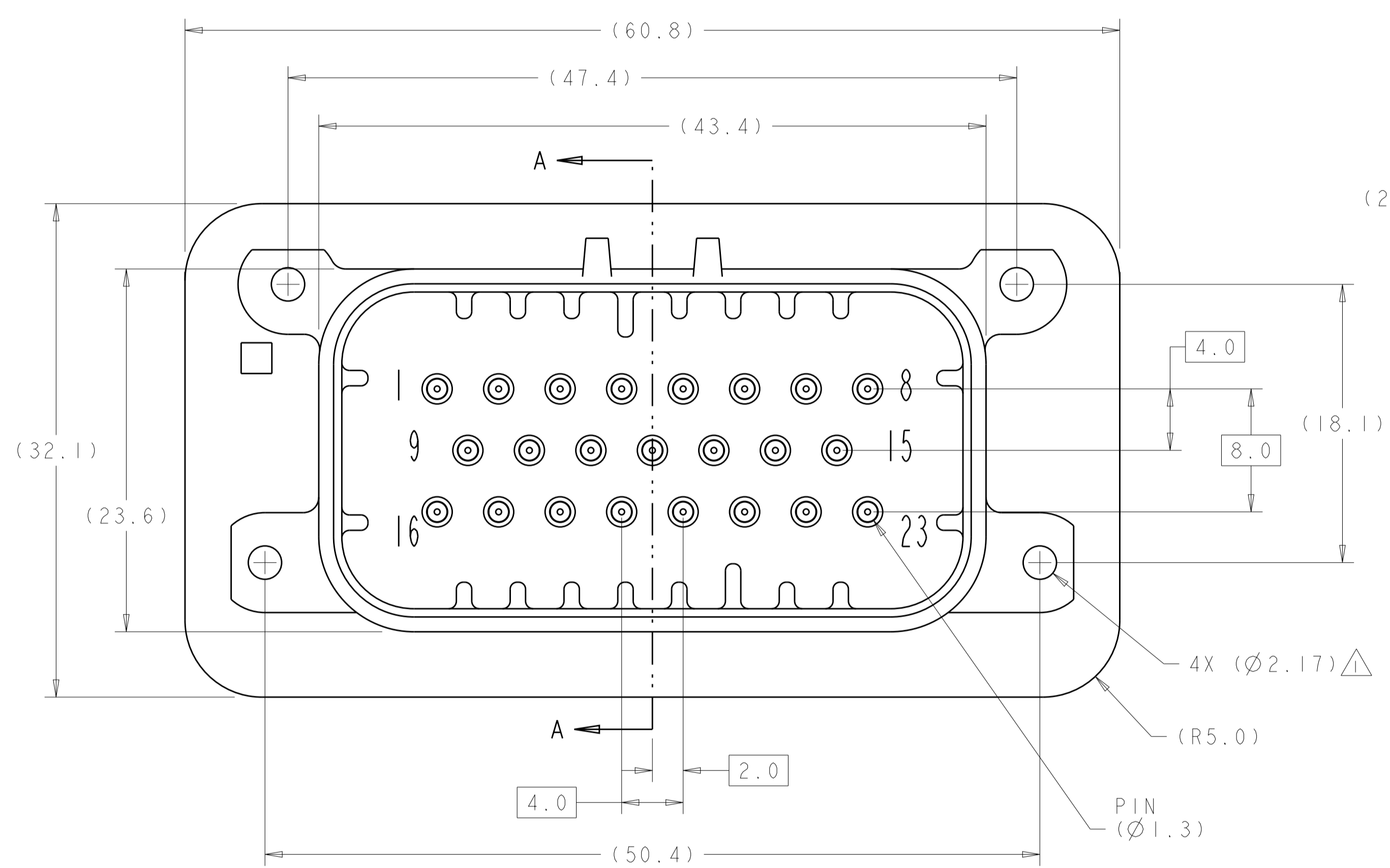

SECTION A-A

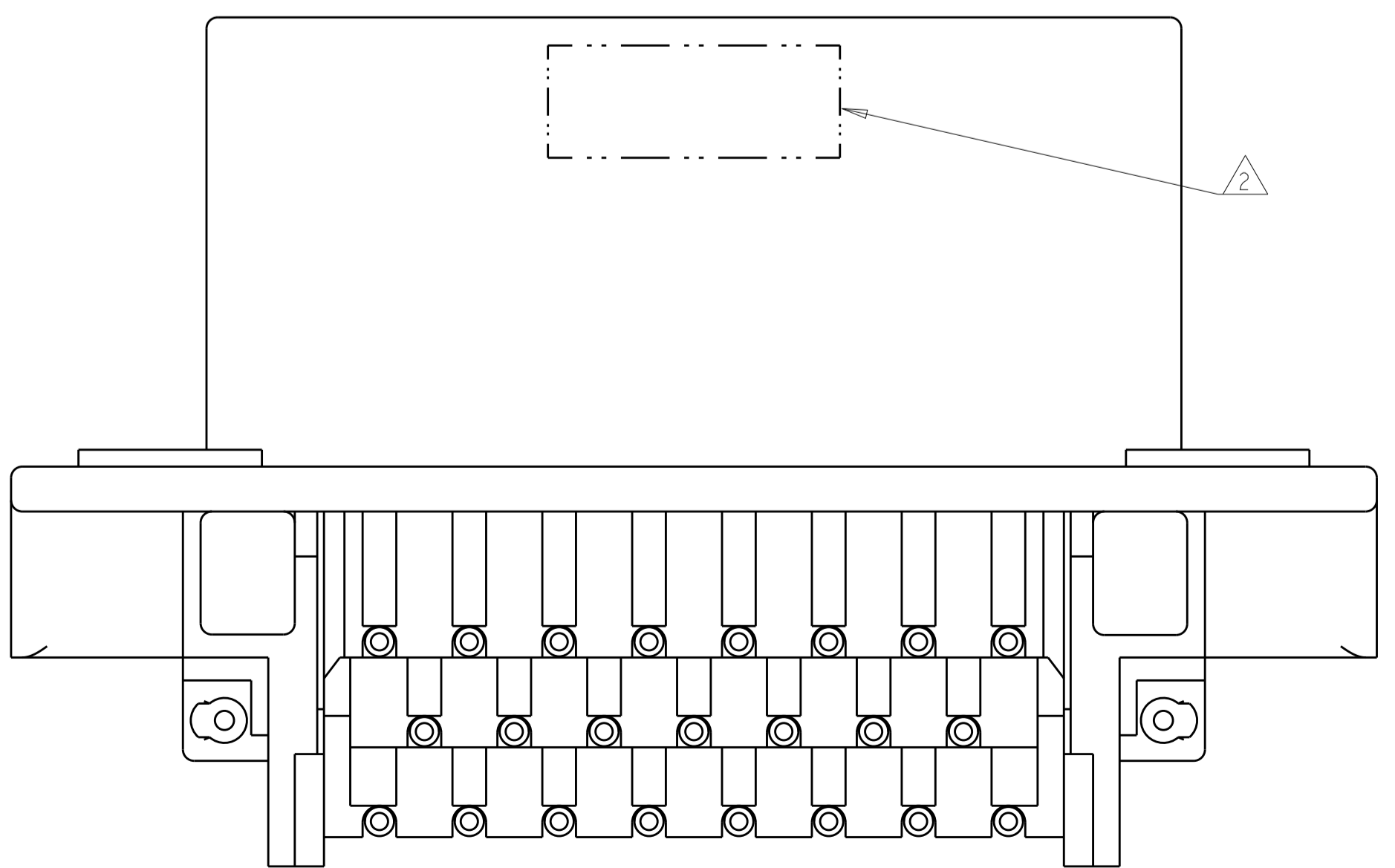

770669-1 & 1-770669-1
 KEY LOCATION AS SHOWN

DURAGOLD	BLUE	1-770669-5
DURAGOLD	GRAY	1-770669-4
DURAGOLD	NATURAL	1-770669-2
DURAGOLD	BLACK	1-770669-1
TIN	BLUE	770669-5
TIN	GRAY	770669-4
TIN	NATURAL	770669-2
TIN	BLACK	770669-1
PLATING	HEADER COLOR/3	PART NUMBER

THIS DRAWING IS A CONTROLLED DOCUMENT. DWN: R. VESTAL 31DEC2002
 CHK: D. CROWE 31DEC2002
 APPV: D. CROWE 31DEC2002

DIMENSIONS: mm
 TOLERANCES UNLESS OTHERWISE SPECIFIED:
 0 PLC ±0.2
 1 PLC ±0.2
 2 PLC ±0.2
 3 PLC ±0.2
 4 PLC ±0.2
 ANGLES ±0.5

MATERIAL: FINISH: 4

PRODUCT SPEC: 108-1329
 APPLICATION SPEC: 114-16016
 WEIGHT: -

CUSTOMER DRAWING

NAME: HEADER ASSEMBLY, 23 POSITION, RIGHT ANGLE AMPSEAL
 SIZE: A1
 CAGE CODE: 100779
 DRAWING NO: 770669
 RESTRICTED TO: -

SCALE: 2:1 SHEET 1 OF 2 REV: K11

REVISIONS				
P.	LTN.	DESCRIPTION	DATE	APVD.
-	-	SEE SHEET 1	-	-

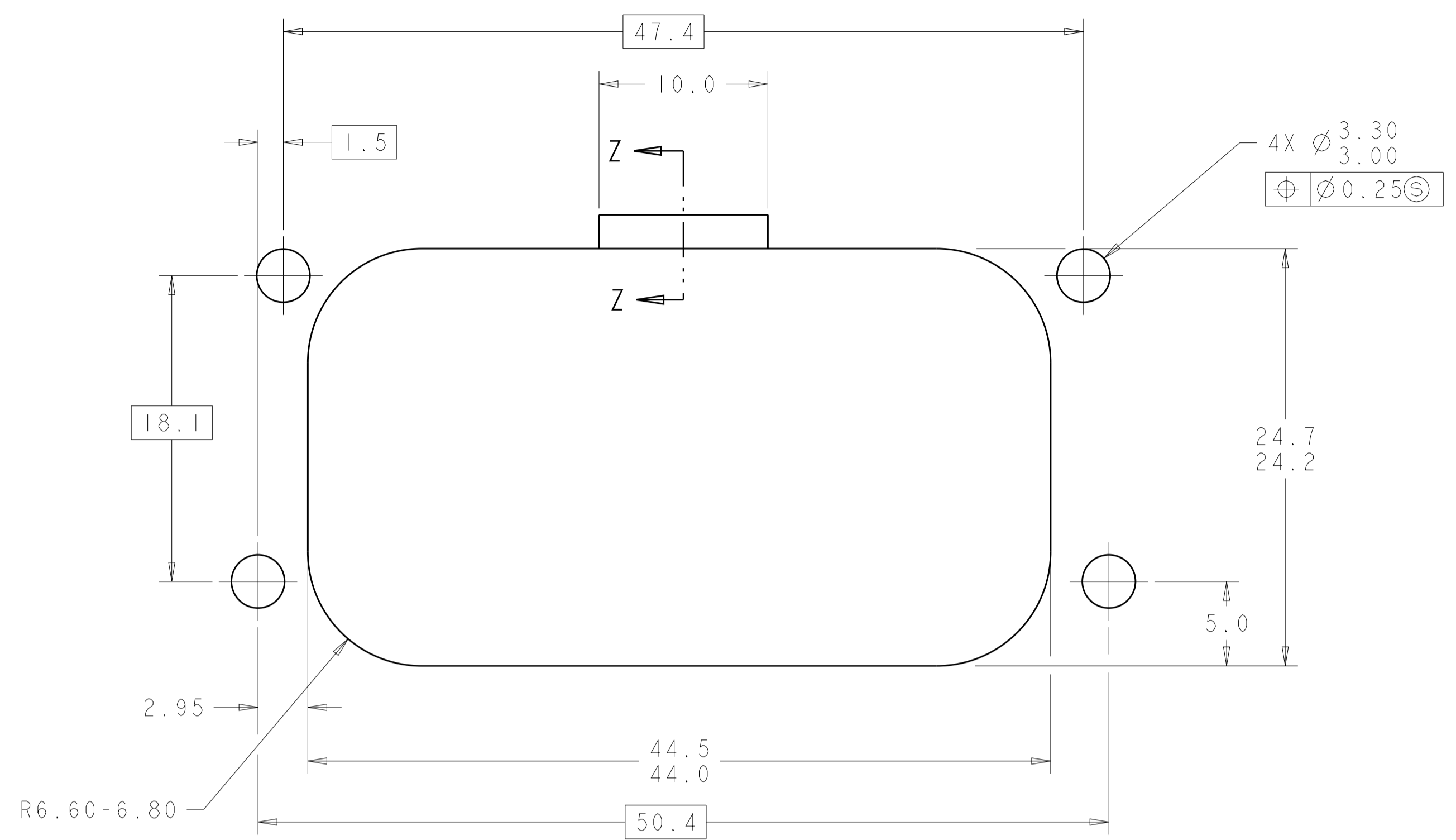

RECOMMENDED MOUNTING HOLE LAYOUT FOR 5.0 MAX THICK PANEL

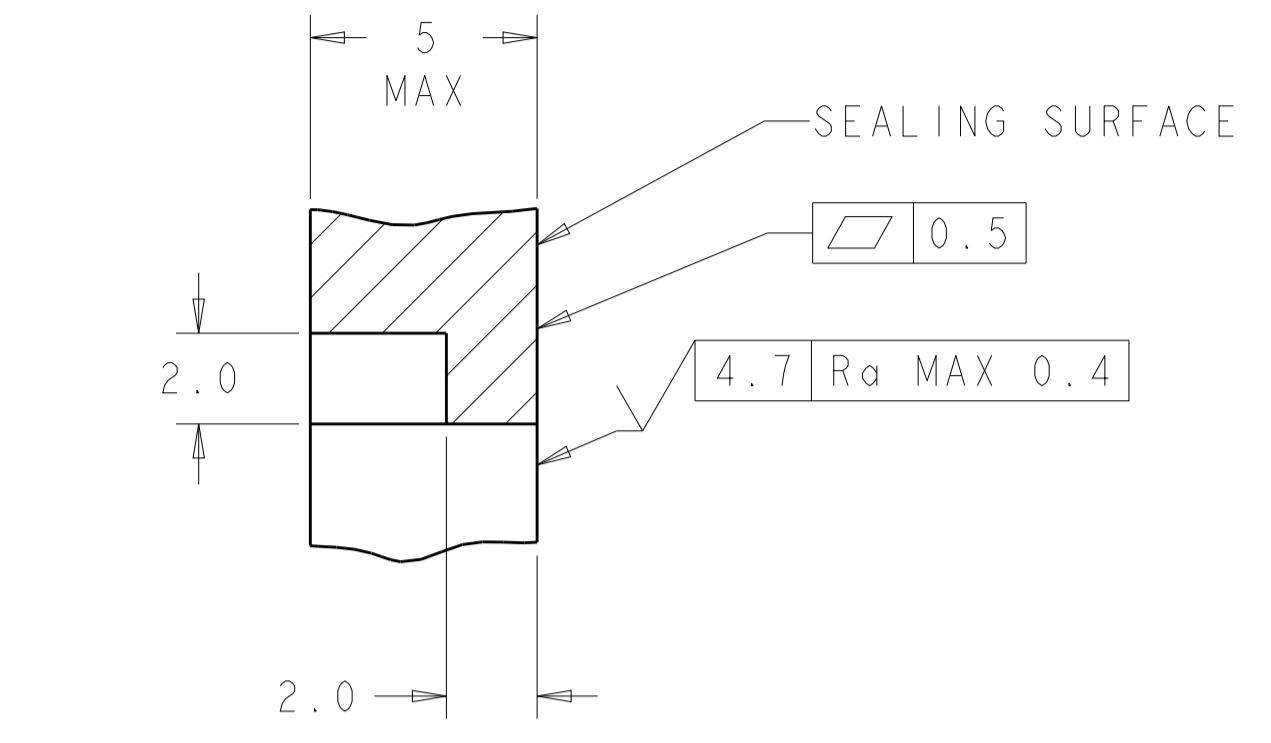

SECTION Z-Z
 OPTIONAL CONSTRUCTION IF THICKNESS IS GREATER THAN 2.0
 SCALE 6:1

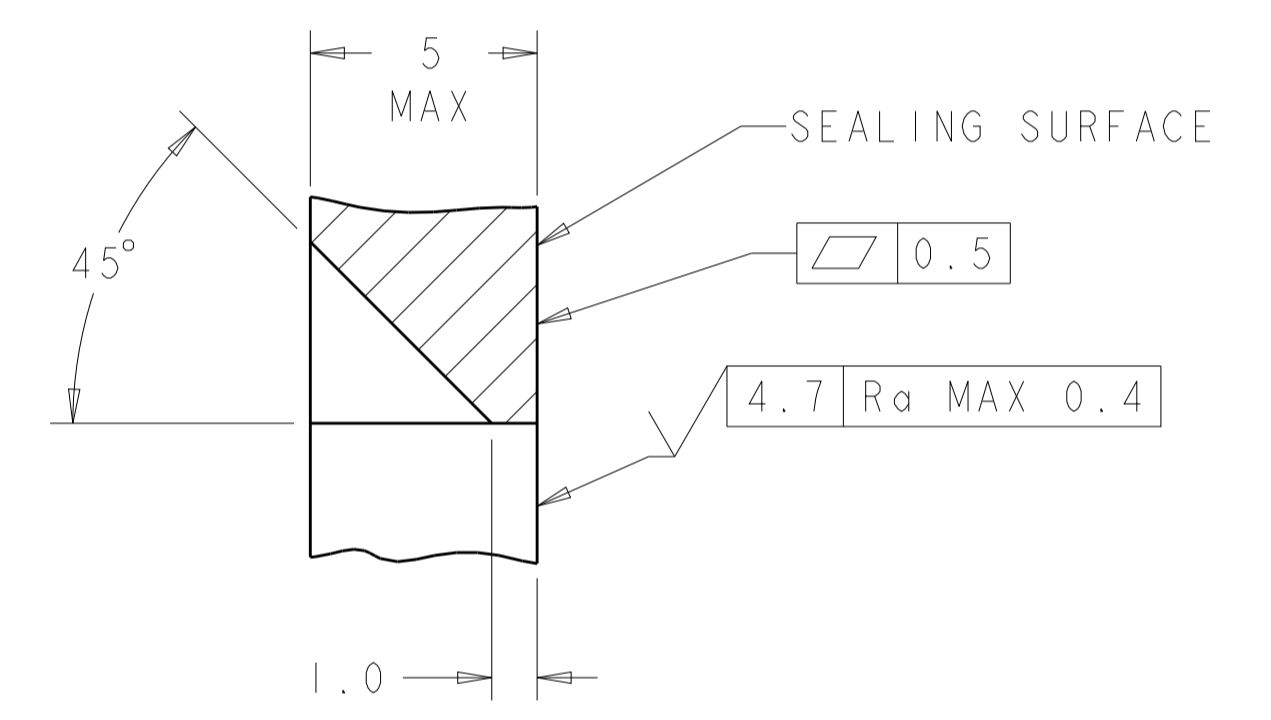

SECTION Z-Z
 OPTIONAL CONSTRUCTION IF THICKNESS IS GREATER THAN 2.0
 SCALE 6:1

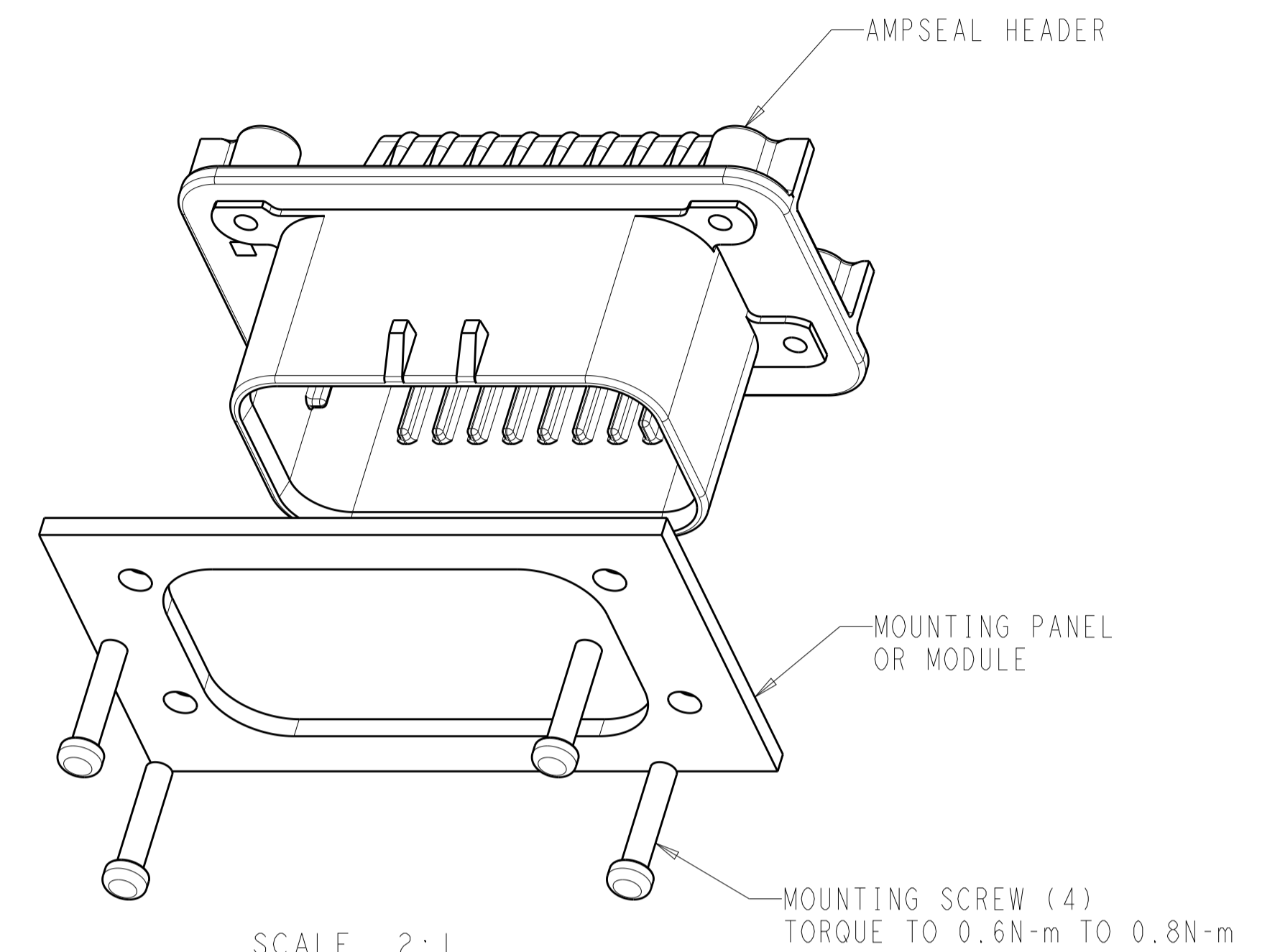

SCALE 2:1

MOUNTING SCREW (4)
 TORQUE TO 0.6N-m TO 0.8N-m

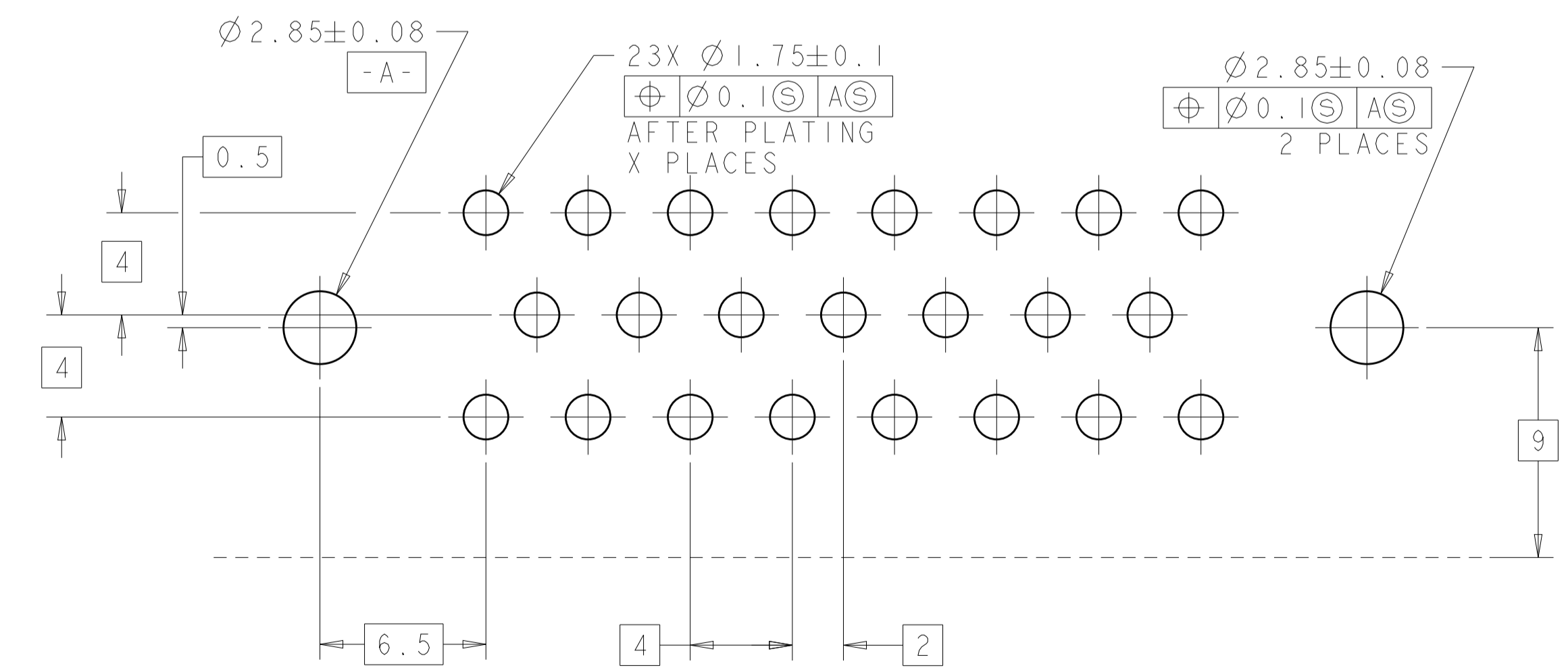

RECOMMENDED P.C. BOARD LAYOUT FOR 1.57 THICK P.C. BOARD

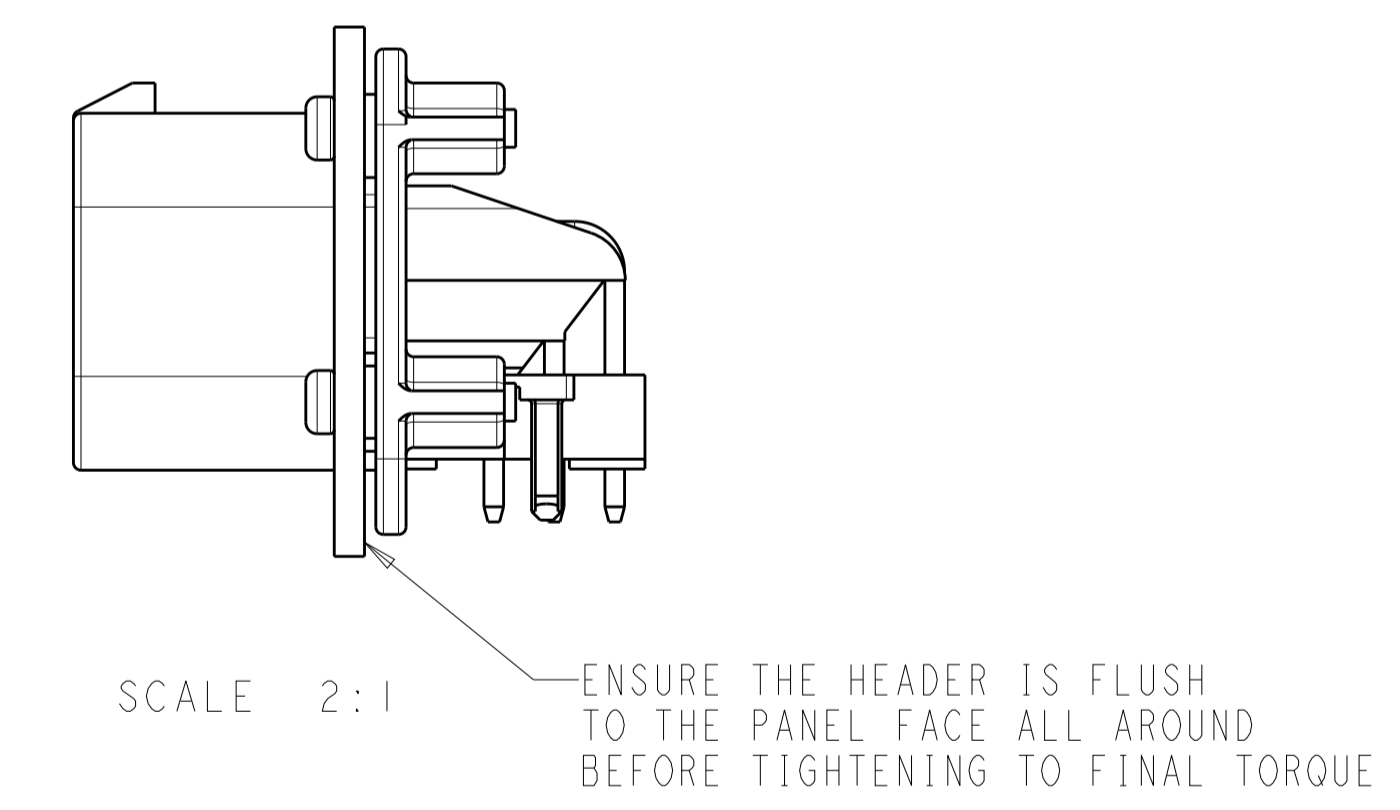

SCALE 2:1

ENSURE THE HEADER IS FLUSH TO THE PANEL FACE ALL AROUND BEFORE TIGHTENING TO FINAL TORQUE

THIS DRAWING IS A CONTROLLED DOCUMENT.		DWN: R. VESTAL 31DEC2002	TE Connectivity
DIMENSIONS: mm		CHK: D. CROWE 31DEC2002	
TOLERANCES UNLESS OTHERWISE SPECIFIED:		APVD: D. CROWE 31DEC2002	NAME: HEADER ASSEMBLY, 23 POSITION, RIGHT ANGLE AMPSEAL
0 PLC	±	PRODUCT SPEC	SIZE: CAGE CODE DRAWING NO
1 PLC	±0.2	108-1329	RESTRICTED TO
2 PLC	±	APPLICATION SPEC	A100779C=770669
3 PLC	±	114-16016	SCALE 2:1 SHEET 2 OF 2 REV K11
4 PLC	±	WEIGHT	
ANGLES	±	CUSTOMER DRAWING	
FINISH	±		